

10 9 8 7 6 5 4 3 2 1

F

F

E

E

D

D

C

C

B

B

A

A



53261-****	WAFER ASSY	MODEL NO./MATERIAL NO.
50079-****	TERMINAL	
51021-****	HOUSING	

RELEASED EC NO: J2006-2426 DRWN: A0YAGI 2006/02/02 CHKD: YMAEDA 2006/02/03 APPR: NUKITA 2006/02/07	GENERAL TOLERANCES (UNLESS SPECIFIED)		DIMENSION STYLE MM ONLY		SCALE ---	DESIGN UNITS METRIC	THIRD ANGLE PROJECTION	
	10 UNDER	± ---	DRAWN BY Y. A0YAGI	DATE 2006/01/30	TITLE 1.25 W-TO-B CONN. 51021,53261 MATING CROSS SECTION			
	10 OVER 30 UNDER	± ---	CHECKED BY Y. MAEDA	DATE 2006/01/30	MOLEX INCORPORATED			
	30 OVER	± ---	APPROVED BY N. UKITA	DATE 2006/01/30	DOCUMENT NO. SD-51021-002			
	ANGULAR	± --- °	MATERIAL NO. SEE CHART		SHEET NO. 1 OF 1			
0	DRAFT WHERE APPLICABLE MUST REMAIN WITHIN DIMENSIONS		SIZE A3		THIS DRAWING CONTAINS INFORMATION THAT IS PROPRIETARY TO MOLEX INCORPORATED AND SHOULD NOT BE USED WITHOUT WRITTEN PERMISSION			

9

8

7

6

5

4

3

2

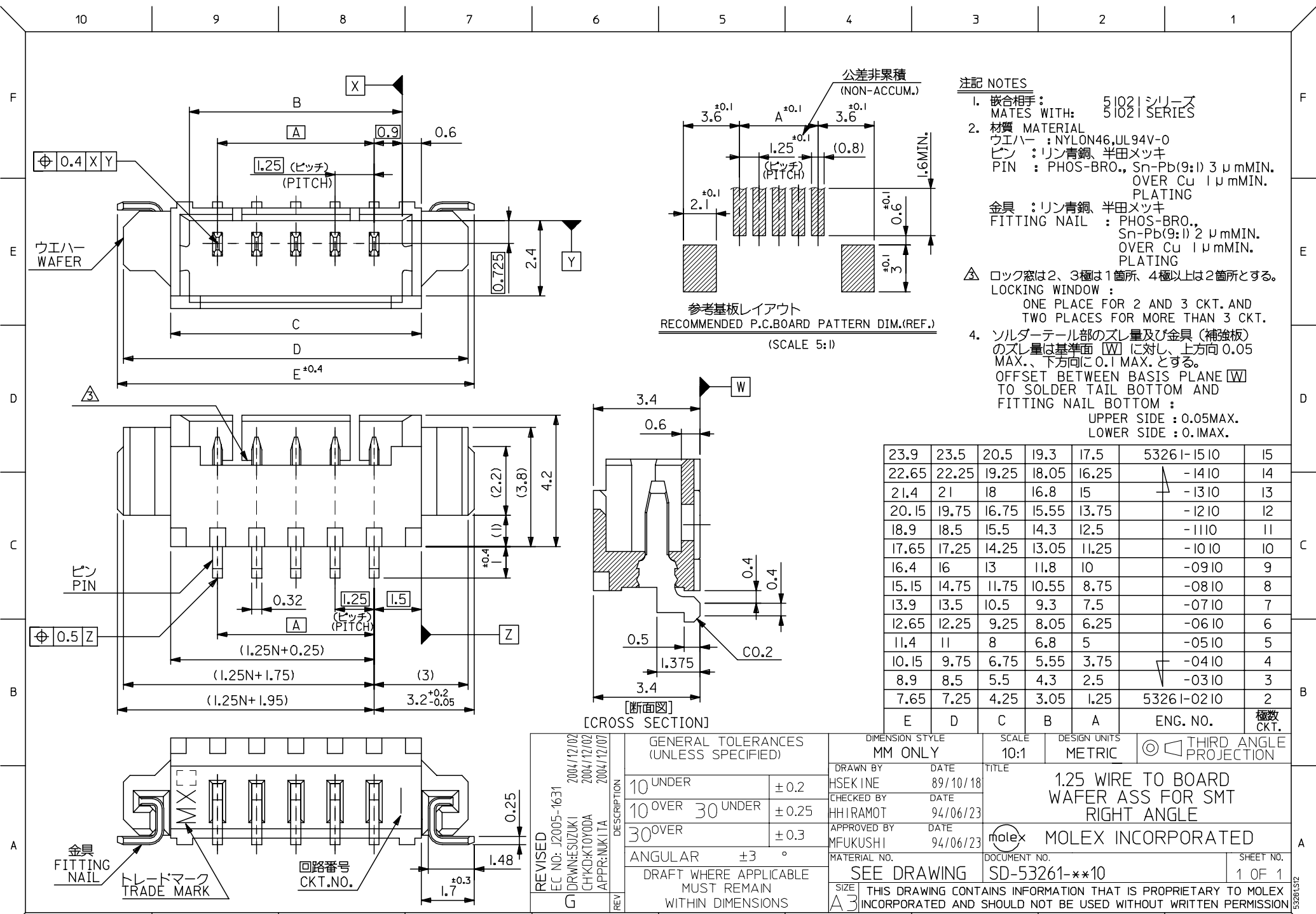

- 注記 NOTES**
1. 嵌合相手: 51021 シリズ
MATES WITH: 51021 SERIES
 2. 材質 MATERIAL
ワエハー: NYLON46, UL94V-0
ピン: リン青銅, 半田メッキ
PIN: PHOS-BRO., Sn-Pb(9:1) 3 μmMIN.
OVER Cu 1 μmMIN.
PLATING
金具: リン青銅, 半田メッキ
FITTING NAIL: PHOS-BRO., Sn-Pb(9:1) 2 μmMIN.
OVER Cu 1 μmMIN.
PLATING
 - △ ロック窓は2、3極は1箇所、4極以上は2箇所とする。
LOCKING WINDOW: ONE PLACE FOR 2 AND 3 CKT. AND TWO PLACES FOR MORE THAN 3 CKT.
 4. ソルダータール部のスレ量及び金具(補強板)のスレ量は基準面 [W] に対し、上方向0.05 MAX.、下方向に0.1 MAX.とする。
OFFSET BETWEEN BASIS PLANE [W] TO SOLDER TAIL BOTTOM AND FITTING NAIL BOTTOM:
UPPER SIDE: 0.05MAX.
LOWER SIDE: 0.1MAX.

23.9	23.5	20.5	19.3	17.5	53261-1510	15
22.65	22.25	19.25	18.05	16.25	-1410	14
21.4	21	18	16.8	15	-1310	13
20.15	19.75	16.75	15.55	13.75	-1210	12
18.9	18.5	15.5	14.3	12.5	-1110	11
17.65	17.25	14.25	13.05	11.25	-1010	10
16.4	16	13	11.8	10	-0910	9
15.15	14.75	11.75	10.55	8.75	-0810	8
13.9	13.5	10.5	9.3	7.5	-0710	7
12.65	12.25	9.25	8.05	6.25	-0610	6
11.4	11	8	6.8	5	-0510	5
10.15	9.75	6.75	5.55	3.75	-0410	4
8.9	8.5	5.5	4.3	2.5	-0310	3
7.65	7.25	4.25	3.05	1.25	53261-0210	2
E	D	C	B	A	ENG. NO.	極数 CKT.

GENERAL TOLERANCES (UNLESS SPECIFIED)

10 UNDER	±0.2
10 OVER 30 UNDER	±0.25
30 OVER	±0.3
ANGULAR	±3 °

DRAFT WHERE APPLICABLE MUST REMAIN WITHIN DIMENSIONS

DIMENSION STYLE: MM ONLY

SCALE: 10:1

DESIGN UNITS: METRIC

THIRD ANGLE PROJECTION

REVISED EC NO: J2005-1631 2004/12/02
 DRAWN: SUZUKI 2004/12/02
 CHYK: K10YODA 2004/12/02
 APPR: NUKITA 2004/12/07

DESCRIPTION: 1.25 WIRE TO BOARD WAFER ASS FOR SMT RIGHT ANGLE

DRAWN BY: HSEKINE DATE: 89/10/18
 CHECKED BY: HHIRAMOT DATE: 94/06/23
 APPROVED BY: MFUKUSHI DATE: 94/06/23

MATERIAL NO. SEE DRAWING
 DOCUMENT NO. SD-53261-**10
 SHEET NO. 1 OF 1

SIZE: A3 THIS DRAWING CONTAINS INFORMATION THAT IS PROPRIETARY TO MOLEX INCORPORATED AND SHOULD NOT BE USED WITHOUT WRITTEN PERMISSION

E

D

C

B

A

MM

DIMENSIONS IN METRIC DO NOT SCALE DRAWING

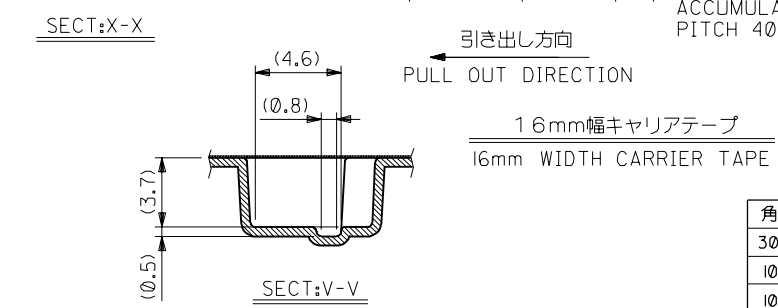
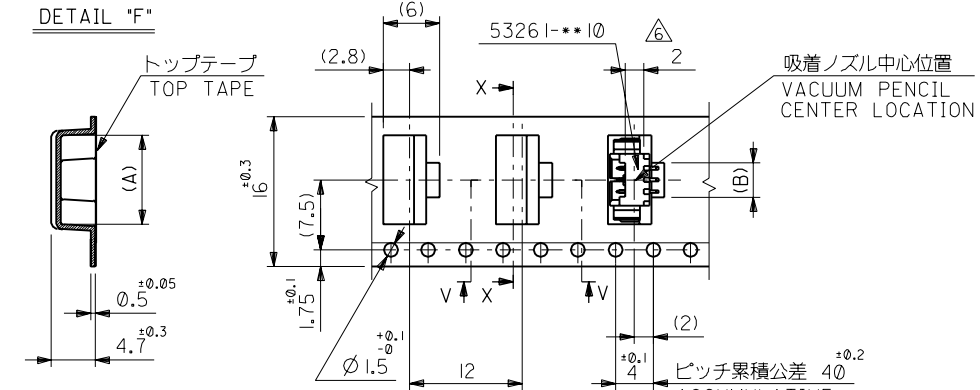
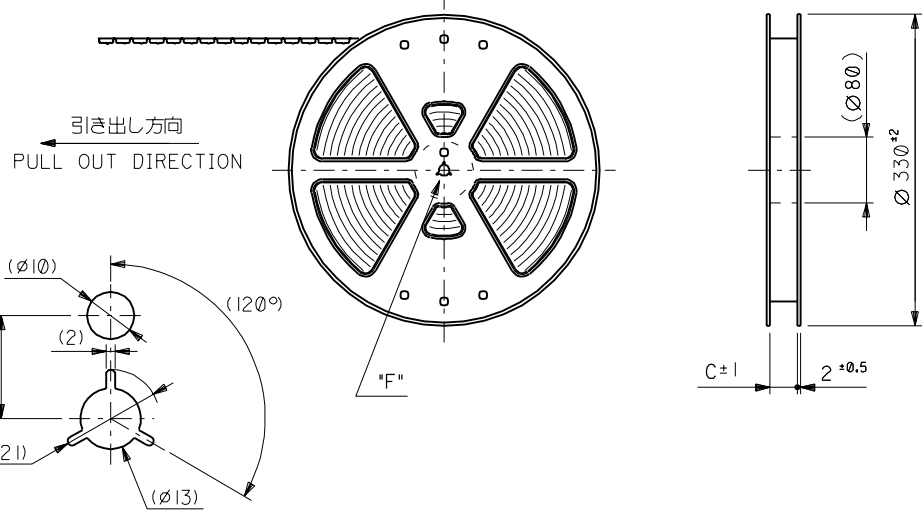

注記 NOTES

- 53261-***10 の詳細寸法については図面 SD-53261-***10 を参照下さい。
RE DETAILED DIMENSIONS, SEE SD-53261-***10.
 - 梱包数量：1000個/リール
NUMBER OF CONNECTOR: 1000PCS/REEL
 - リードテープ長さ LEAD TAPE LENGTH
 トップテープリーダー部 TOP TAPE LEADER PART 175 ±2.5
 トップテープ未接着部 TOP TAPE NON-BONDED PART 25 ±5
-
- トップテープの剥離強度：0.1IN～0.59N(10.2～60gf) (剥離方向は下図参照)
PEELING OFF FORCE OF TOP TAPE: 0.1IN～0.59N(10.2～60gf)
(PEELING DIRECTION IS SHOWN IN FOLLOWING FIG.)
 <剥離速度：300mm/min (参考)>
 PEELING SPEED: 300mm/min. (REFERENCE)
 10°
 剥離方向 PEEL OFF DIRECTION
 - 材料 (MATERIAL)
 キャリアテープ (CARRIER TAPE): ポリプロピレン (POLYPROPYLENE)
 トップテープ (TOP TAPE): PET, PE, PEF
 リール (REEL): ポリスチレン (PS) <リサイクル材含む>
 POLYSTYRENE (PS) <RECYCLE MATERIAL CONTAINED>
- △ コネクタ、ハウジング平面部
CONNECTOR, HOUSING FLAT AREA

16	16.4	3.7	9.5	53261-0390	3
キャリアテープ幅 CARRIER TAPE WIDTH	C	2.45	8.25	53261-0290	2
材料 MATERIAL	注記参照 SEE NOTES		molex MOLEX-JAPAN CO.,LTD. 日本モレックス株式会社		
仕上げ FINISH	—		REVISE ONLY ON CAD SYSTEM		
適用電線範囲 WIRE RANGE	—		TITLE 名称 1.25 WIRE TO BOARD CONN. WAFER ASS'Y FOR SMT. EMBOSSED TAPE PACKAGE		
被覆外径 INS. RANGE	—		DWG. NO. SHEET 1 OF 3 REV SD-53261-***90		
DRAWN BY '93/6/1 K.TOJO	CHK'D BY '00/12/8 T.YAMAGUCHI	SCALE —			
APP'D BY '00/12/8 M.FUKUSHIMA	R.D.R.				

角度 ANGLE	±3°				
30以上 OVER	+0.3				
10以上 30未満 OVER UNDER	+0.25	F	変更 REVISED	(C2001-0437)	S.M. '00/12/8
10未満 UNDER	+0.2	E	変更及び再作図 REVISED&REDRAWN	(J30522)	K.T. '93/6/1
一般公差 GENERAL TOLERANCES		記号 LTR	変更内容 REVISION RECORD	DR. CHK.	日付 DATE

DWG. NO. SD-53261-***90

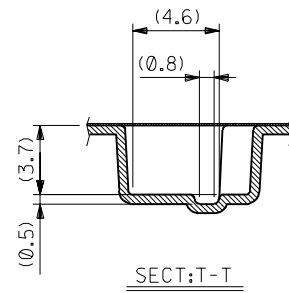
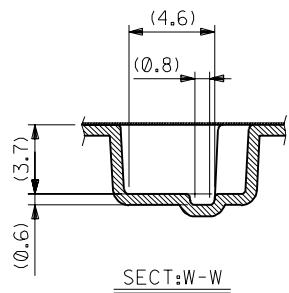
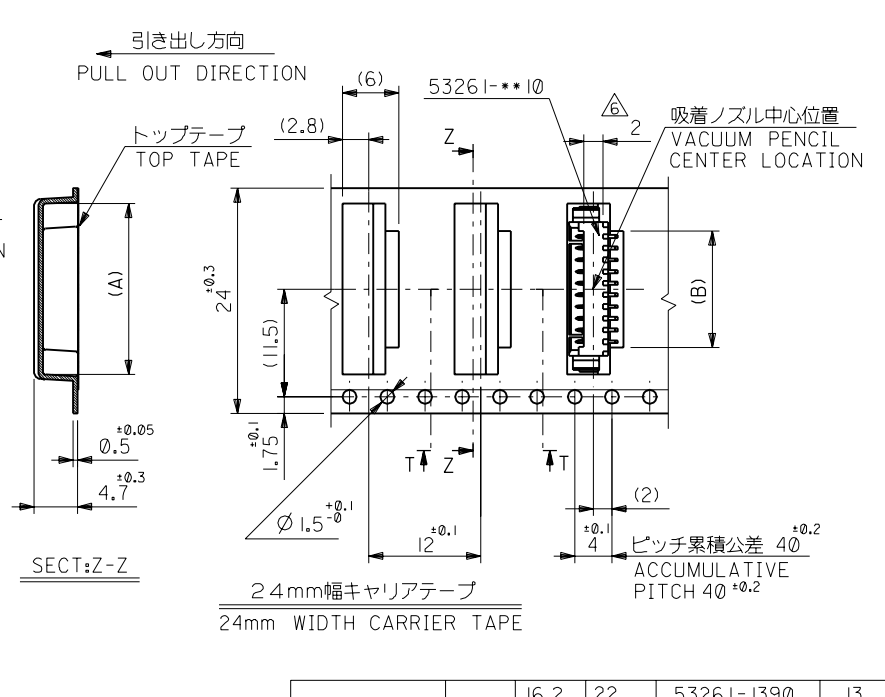
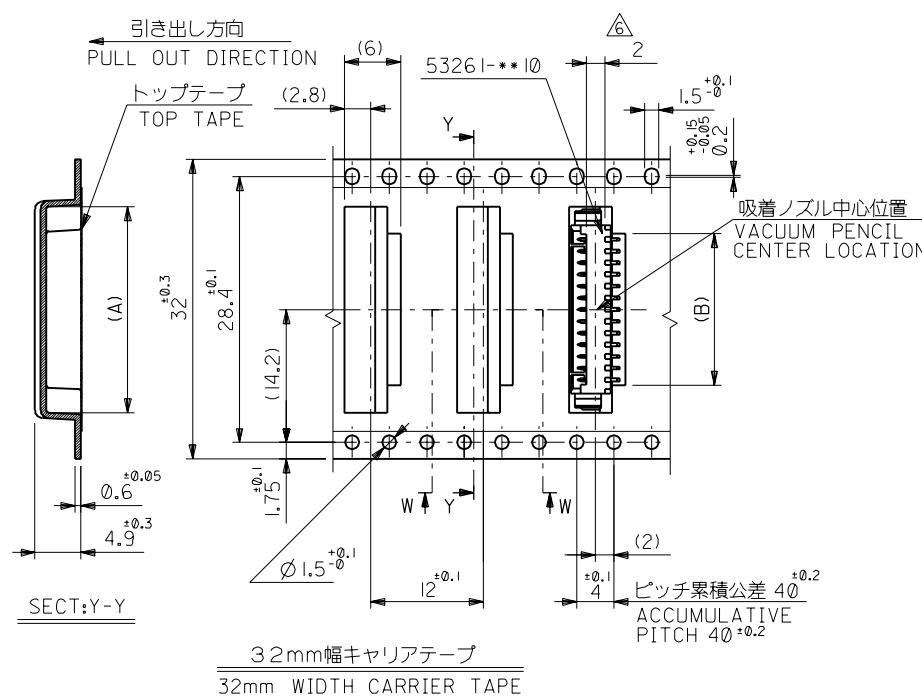

32	32.4	16.2	22	53261-1390	13
		14.95	20.75	-1290	12
24	24.4	13.7	19.5	-1190	11
		12.45	18.25	-1090	10
		11.2	17	-0990	9
		9.95	15.75	-0890	8
		8.7	14.5	-0790	7
		7.45	13.25	-0690	6
		6.2	12	-0590	5
4.95	10.75	53261-0490	4		
キャリアテープ幅 CARRIER TAPE WIDTH	C	B	A	ENG. NO.	極致 CKT.

材料 MATERIAL	注記参照 SEE NOTES	材料 MATERIAL	注記参照 SEE NOTES
仕上げ FINISH	—	材料 MATERIAL	注記参照 SEE NOTES
適用電線範囲 WIRE RANGE	—	材料 MATERIAL	注記参照 SEE NOTES
被覆外径 INS. RANGE	—	材料 MATERIAL	注記参照 SEE NOTES
角度 ANGLE	±3°	材料 MATERIAL	注記参照 SEE NOTES
30以上 OVER	+0.3	材料 MATERIAL	注記参照 SEE NOTES
10以上 30未満 UNDER	+0.25	材料 MATERIAL	注記参照 SEE NOTES
10未満 UNDER	+0.2	材料 MATERIAL	注記参照 SEE NOTES
一般公差 GENERAL TOLERANCES	記号 LTR	材料 MATERIAL	注記参照 SEE NOTES
	変更内容 REVISION RECORD	材料 MATERIAL	注記参照 SEE NOTES
	DR. DATE	材料 MATERIAL	注記参照 SEE NOTES
	CHK. DATE	材料 MATERIAL	注記参照 SEE NOTES

材料 MATERIAL	注記参照 SEE NOTES	材料 MATERIAL	注記参照 SEE NOTES
仕上げ FINISH	—	材料 MATERIAL	注記参照 SEE NOTES
適用電線範囲 WIRE RANGE	—	材料 MATERIAL	注記参照 SEE NOTES
被覆外径 INS. RANGE	—	材料 MATERIAL	注記参照 SEE NOTES
角度 ANGLE	±3°	材料 MATERIAL	注記参照 SEE NOTES
30以上 OVER	+0.3	材料 MATERIAL	注記参照 SEE NOTES
10以上 30未満 UNDER	+0.25	材料 MATERIAL	注記参照 SEE NOTES
10未満 UNDER	+0.2	材料 MATERIAL	注記参照 SEE NOTES
一般公差 GENERAL TOLERANCES	記号 LTR	材料 MATERIAL	注記参照 SEE NOTES
	変更内容 REVISION RECORD	材料 MATERIAL	注記参照 SEE NOTES
	DR. DATE	材料 MATERIAL	注記参照 SEE NOTES
	CHK. DATE	材料 MATERIAL	注記参照 SEE NOTES

THIS DRAWING CONTAINS INFORMATION THAT IS PROPRIETARY TO MOLEX(JAPAN) AND SHOULD NOT BE USED WITHOUT WRITTEN PERMISSION
 本図面は日本モレックス(株)の所有する情報を含むもので 当社の許可なく複製を禁止する。 EN-01C(032)MXJ-32

E

D

C
B
A
DIMENSIONS IN METRIC DO NOT SCALE DRAWING

A

8 7 6 5 4 3 2 1

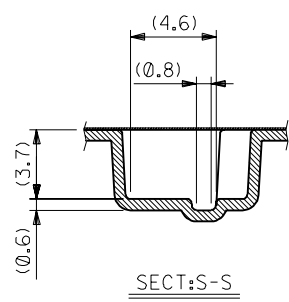
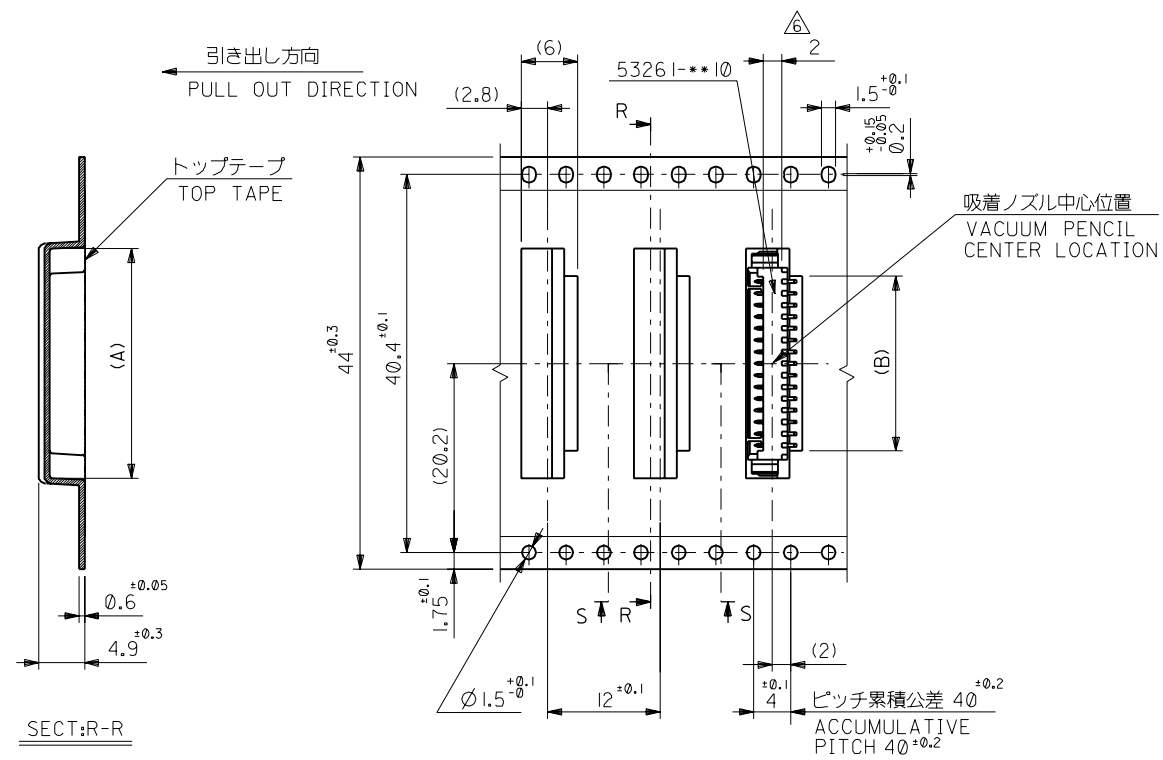

44mm幅キャリアテープ
44mm WIDTH CARRIER TAPE

44	44.4	18.7	24.5	53261-1590	15
キャリアテープ幅 CARRIER TAPE WIDTH	C	B	A	ENG. NO.	極致 CKT.
材料 MATERIAL		注記参照 SEE NOTES		molex MOLEX-JAPAN CO.,LTD. 日本モレックス株式会社	
仕上げ FINISH		—		REVISE ONLY ON CAD SYSTEM	
適用電線範囲 WIRE RANGE		—		TITLE 名称 1.25 WIRE TO BOARD CONN. WAFER ASS'Y FOR SMT. EMBOSSD TAPE PACKAGE	
被覆外径 INS. RANGE		—		DWG. NO. SHEET 3 OF 3 REV SD-53261-***90	
DRAWN BY '93/6/1 K.TOJO		CHK'D BY '00/12/8 T.YAMAGUCHI		F	
APP'D BY '00/12/8 M.FUKUSHIMA		尺度 SCALE		—	

角度 ANGLE	±3°				
30以上 OVER	±0.3				
10以上 30未満 OVER UNDER	±0.25	F	変更 REVISED (J30522)	S.M. T.Y	00/12/8
10未満 UNDER	±0.2	E	変更及び再作図 REVISED&REDRAWN (J30522)	K.T. H.H	'93/6/1
一般公差 GENERAL TOLERANCES		記号 LTR	変更内容 REVISION RECORD	DR. CHK	日付 DATE

8 7 6 5 4 3 2 1